

INSTALLING INSTRUCTIONS

DCG2 – GridLyte

SAVE THESE INSTRUCTIONS

INSTALL AND USE THIS LUMINAIRE FOLLOWING THE NATIONAL ELECTRICAL CODE, YOUR LOCAL ELECTRICAL CODE AND REGULATIONS.

PREPARATION:

- 1). Read and understand instructions completely before installing this luminaire. Installation and electrical wiring of this Luminaire must be done by a qualified licensed electrician.
- 2). Before proceeding with the installation, be sure that the ceiling construction follows the proper requirements.

WARNING- Before starting the wire connections, disconnect the power by turning off the circuit breaker or removing the fuse at the fuse panel. Turning the power off using the light switch is not sufficient to prevent electrical shock. This luminaire must be connected with supply wire rated at 90 C. Most dwellings built before 1985 have supply wire rated at 60 C; consult a qualified electrician before installing.



INSTALLING ELECTRICAL BOX & REMOTE DRIVER BOX:

Install Electrical Box (provided), close to Luminaires location, Each box has 1 to 4 drivers depending on the fixtures lay out & distribution.

INSTALLING INSTRUCTIONS

DCG2 – GridLyte

SAVE THESE INSTRUCTIONS

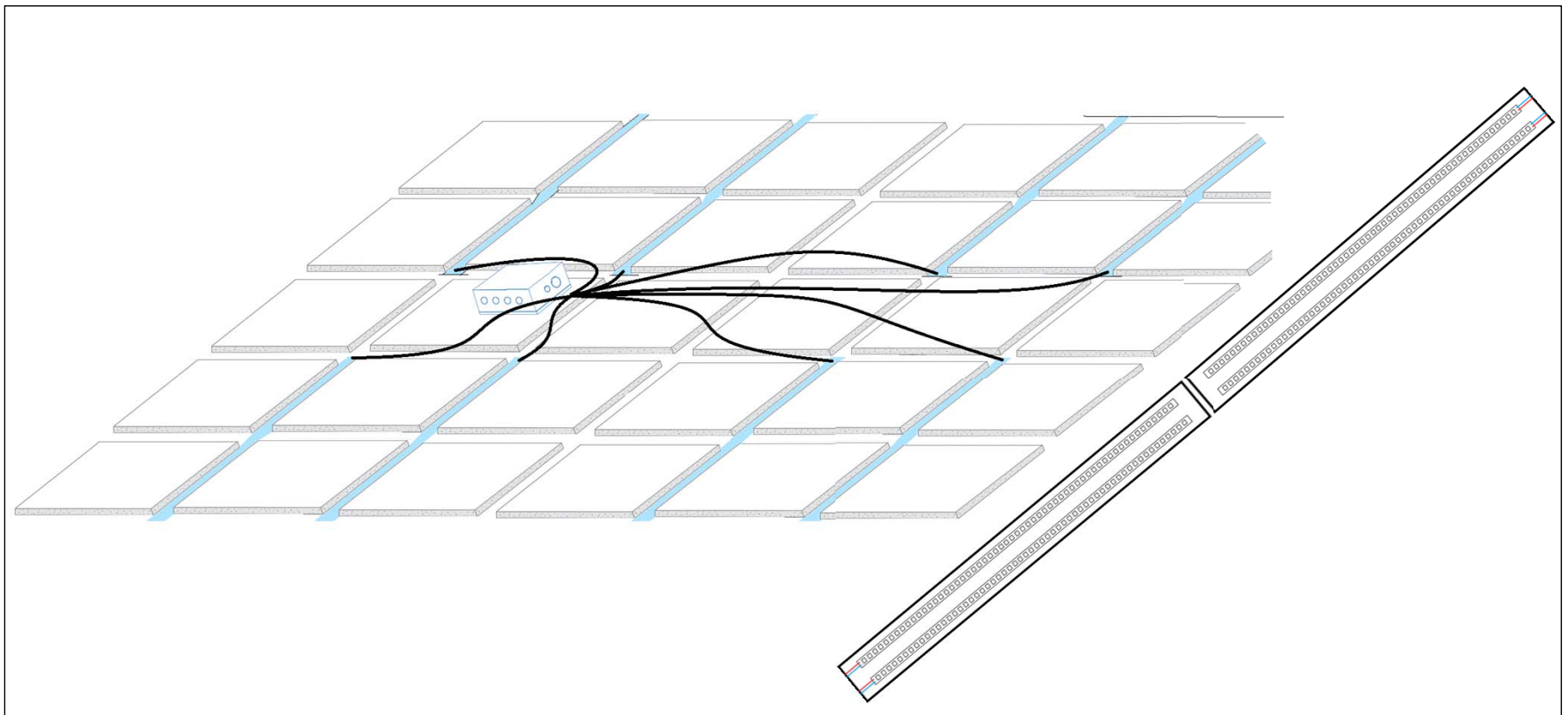

Proceed with electrical connections. See wiring diagrams detailed Below for each

INSTALLING INSTRUCTIONS

DCG2 – GridLyte

SAVE THESE INSTRUCTIONS

DCG2-8-24W-35K-UD

- Every 8ft (In this case, each DCG2-8-24W-35K-UD) profile is powered by two drivers, as shown
- Every 6" x 12" x 6" Remote Driver Box has 4 drivers inside already programmed.

Remote Driver Box (6" x 12" x 6")

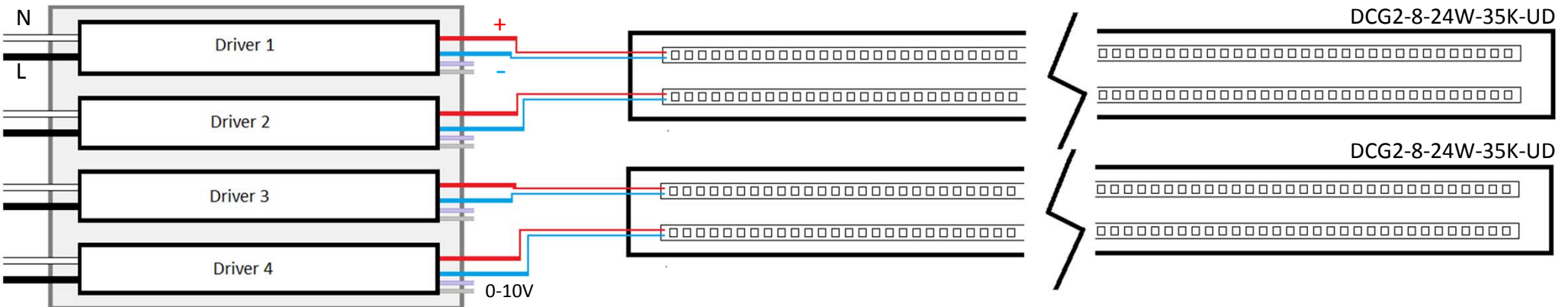

INSTALLING INSTRUCTIONS

DCG2 – GridLyte

SAVE THESE INSTRUCTIONS

DCG2-16-24W-35K-UD

- Every 8ft profile is powered by two drivers as shown
- Every 6" x 12" x 6" Remote Driver Box has 4 drivers inside already programmed.

Remote Driver Box (6" x 12" x 6")

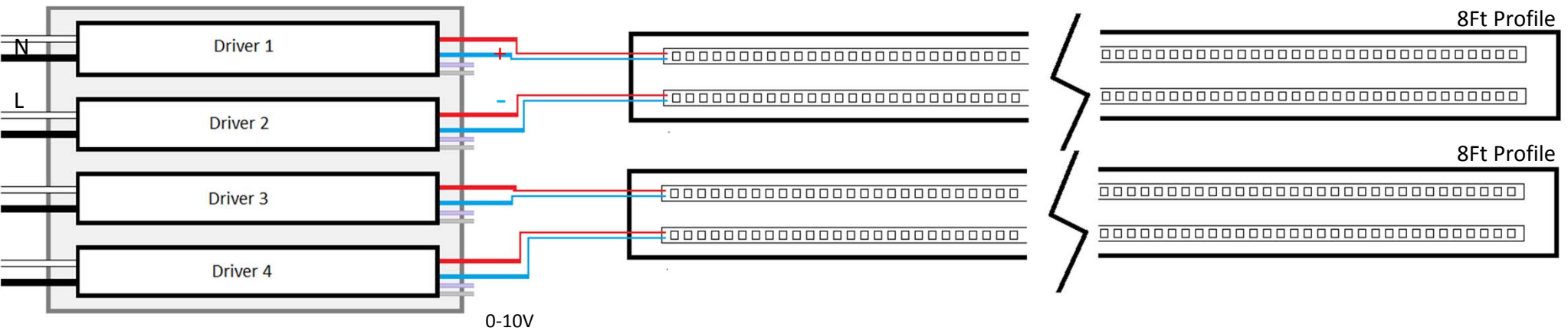

DCG2-16-24W-35K-UD

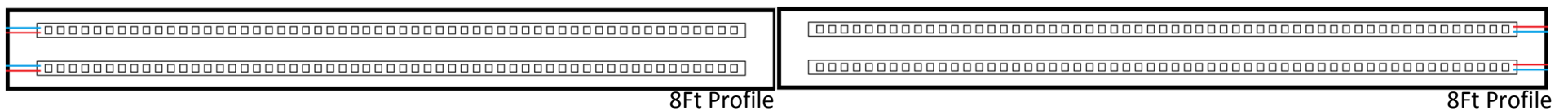

INSTALLING INSTRUCTIONS

DCG2 – GridLyte

SAVE THESE INSTRUCTIONS

DCG2-6.33-24W-35K-UD

- Every 6.33Ft profile is powered by two drivers as shown
- Every 6" x 12" x 6" Remote Driver Box has 4 drivers inside already programmed.

Remote Driver Box (6" x 12" x 6")

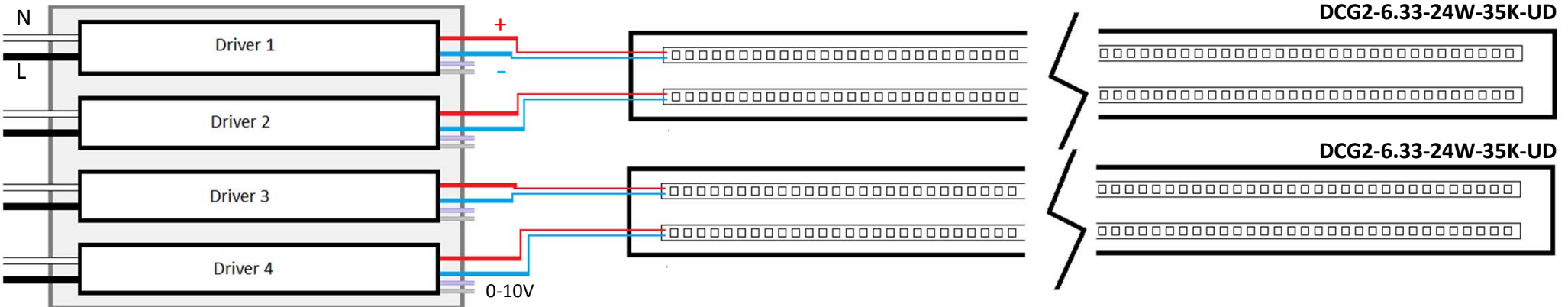

INSTALLING INSTRUCTIONS

DCG2 – GridLyte

SAVE THESE INSTRUCTIONS

DCG2-12-24W-35K-UD

- 8Ft profile is powered by two drivers as shown
- 4Ft profile is powered by one driver as shown
- The 6" x 12" x 6" Remote Driver Box has 3 drivers inside already programmed.

Remote Driver Box (6" x 12" x 6")

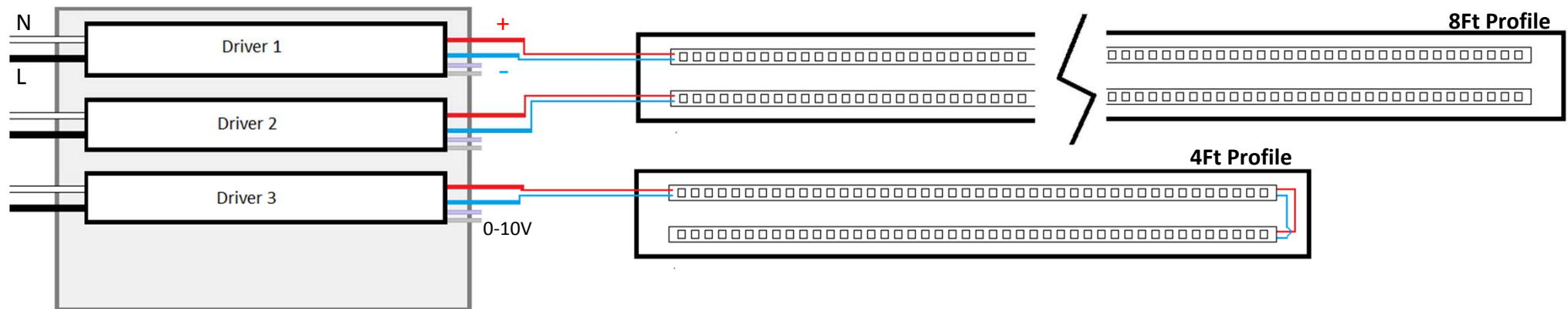

DCG2-12-24W-35K-UD

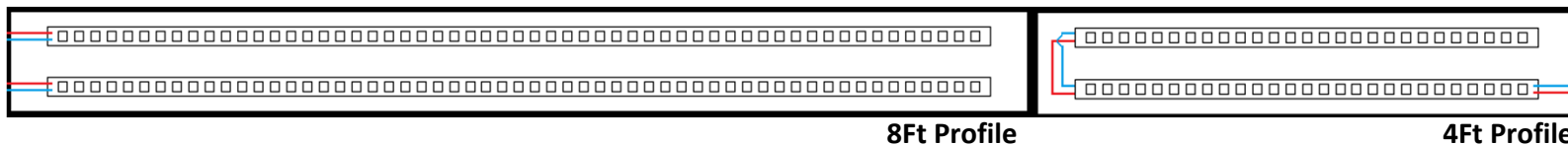

INSTALLING INSTRUCTIONS

DCG2 – GridLyte

SAVE THESE INSTRUCTIONS

DCG2-22-24W-35K-UD

- 8Ft profiles are powered by two drivers as shown
- 6Ft profile is powered by two drivers as shown
- The 6" x 12" x 6" Remote Driver Box has 4 drivers inside already programmed.
- The 6" x 12" x 4" Remote Driver Box has 2 drivers inside already programmed.

Remote Driver Box (6" x 12" x 4")
(only 2 Drivers)



Remote Driver Box (6" x 12" x 6")
(4 Drivers)

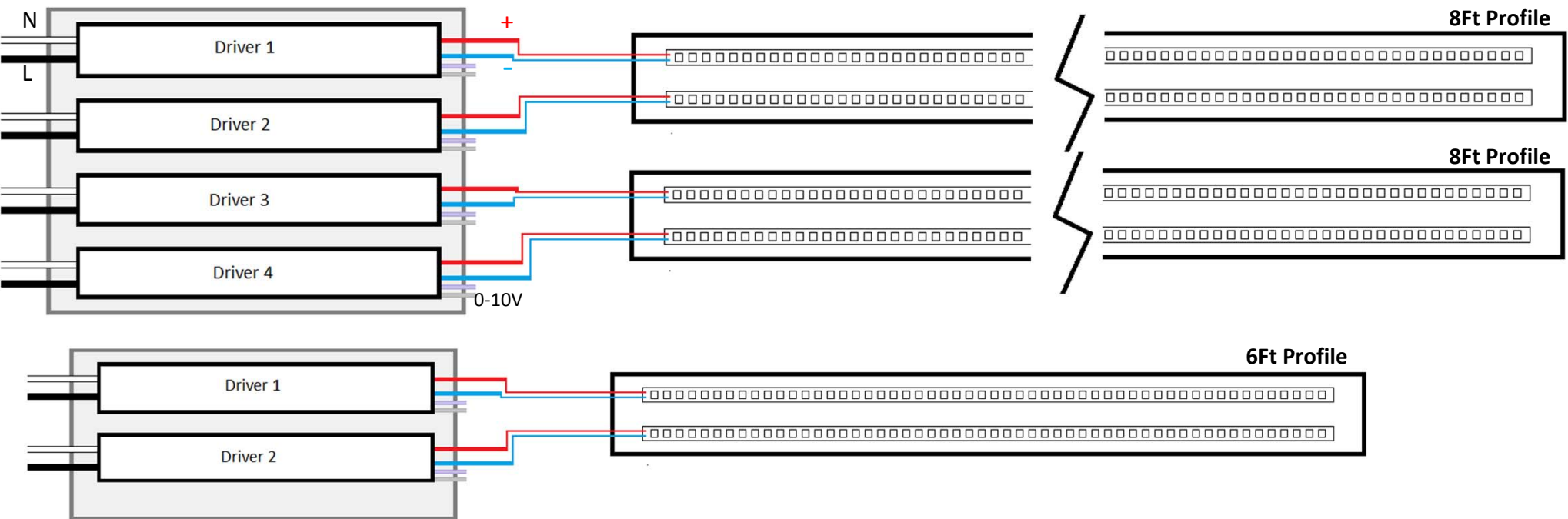

DCG2-22-24W-35K-UD

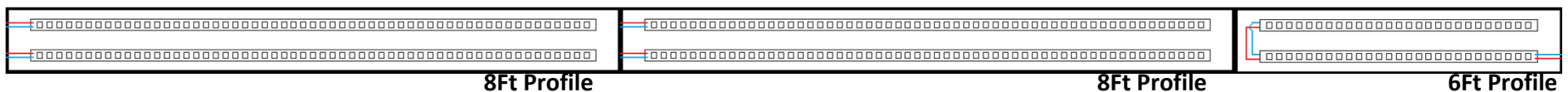

INSTALLING INSTRUCTIONS

DCG2 – GridLyte

SAVE THESE INSTRUCTIONS

INSTALLING THE DCG2

Once Remote drivers Boxes have been installed and properly connected, proceed with the installation of the Fixtures.



Carefully remove the diffuser, starting from one end.



Then, Remove the T-Grid clips provided with the fixtures, save the locknuts to use them once fixture is properly installed.



Install the clip in the T-Grid by pressing, then secure by twist until it is adjusted.

Once Clip is installed slide trough the T-Grid until it is located in the right position considering the fixture holes.

INSTALLING INSTRUCTIONS

DCG1 – GridLyte

SAVE THESE INSTRUCTIONS

INSTALLING THE DCG2

With the 2 or 3 T-Grid clips installed and located in the correct position (based in the holes on the profile), proceed to install the housing of the fixture.



Use the locknuts provided to secure the luminaire



Re-install the diffuser
